

WINX LOUNGE



WX 885.16

Design: Kai Stania

Manufacturer: RIM CZ a.s.

WINX LOUNGE 885.16

Modern, fully-upholstered armchair of rounded shape with armrests, designed for relaxation zones, home offices, waiting areas, entrance halls and receptions.

Precise upholstery work allows for experimenting with colour and material combinations.

Design	<p>Two-part polyurethane shell consists of a base part (structure) and backrest.</p> <p>The structure is comprised of a frame welded from steel wires and reinforced in the point of connection to the base. The frame is covered with PUR foam, bulk weight of 70 kg/m³.</p> <p>A polyurethane seat, foamed in a mould with a thickness of 80 mm and bulk weight of 65kg/m³, ensures comfortable sitting.</p> <p>The polyurethane foam is free of added CFC's and with reduced flammability as per California Technical Bulletin 117, Section A Part 1 and Section D Part 2.</p>
Base	<p>.16 – wooden, oak or ash wood, painted with clear polyurethane lacquer.</p> <p>Felt glide is used for soft floor (linoleum, PVC, soft wood).</p>
Upholstery	To be selected from fabric collection.
Warranty	5 years (see Business conditions)

Dimensions (in mm)

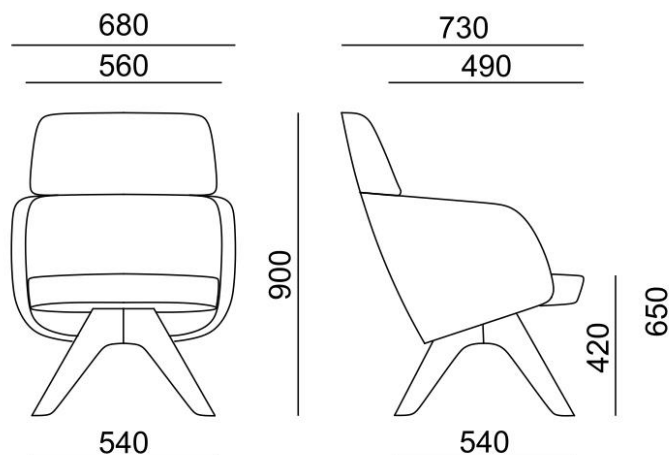



WX 885.01



WX 886.01



WX 886.16